





**800 SF
Available**

KISSIMMEE SQUARE

1301 E. Vine Street, Kissimmee FL 34744



PROPERTY HIGHLIGHTS:

-  Anchored by Presidente Supermarket, Dollar Tree, Cititrends, and Greenberg Dental
-  106,157 SF neighborhood shopping center
-  High Traffic Area: U.S. 192 & Michigan Ave. 50,000AADT
-  Frontage on I-4
-  Located on the corner of U.S. 192 and Michigan Ave.



Janet Galvin
O 407 278 5535 x 404
C 407 484 9562
janet@archonca.com

100 East Central Blvd, Suite #2
Orlando, FL 32801
P 407 278 5535 | F 407 545 2844
www.archonca.com

Stay in the know. Click to follow us on social media.



KISSIMMEE SQUARE

1301 E. Vine Street, Kissimmee FL 34744

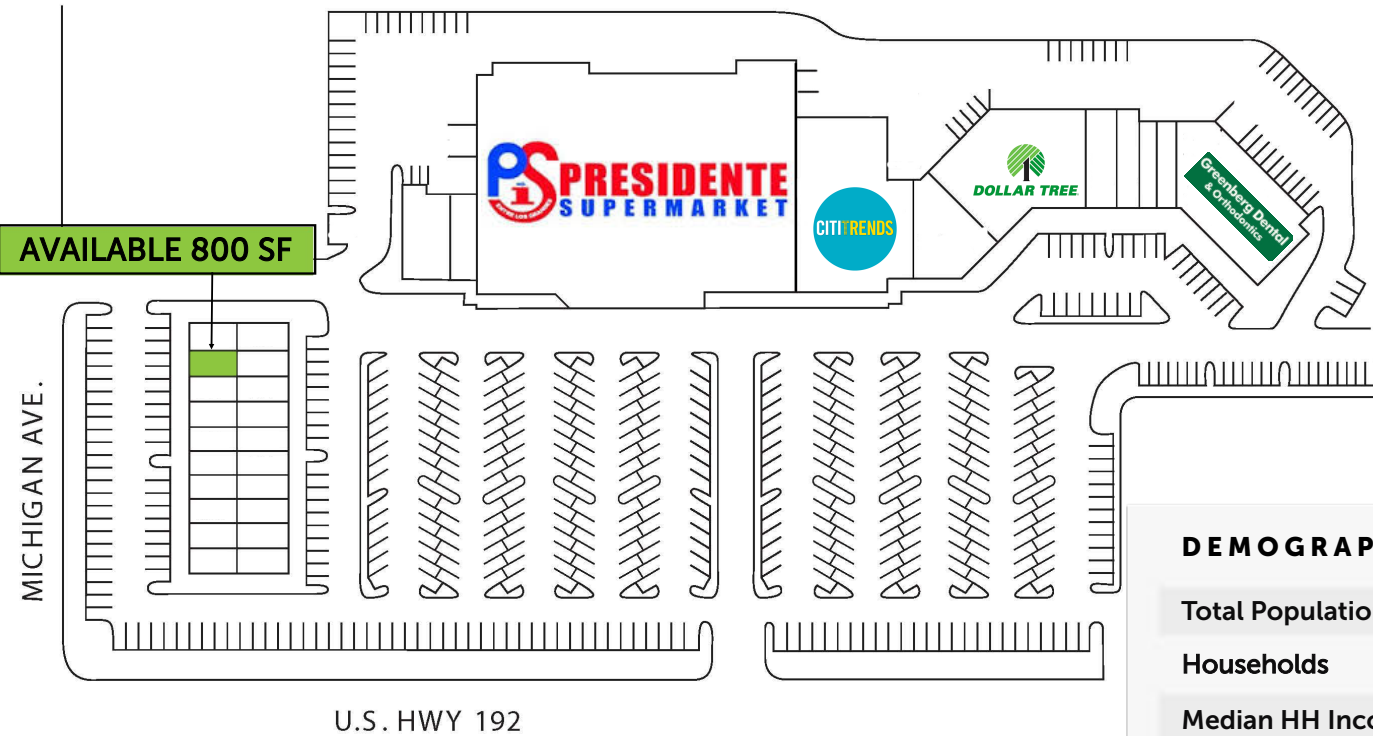

DEMOGRAPHICS	3 Mile	5 Mile	10 Mile
Total Population	96,168	225,418	567,442
Households	31,839	76,399	200,674
Median HH Income	\$61,680	\$56,191	\$60,051
Number of Businesses	2,228	4,800	15,763
Median Age	37.9	38.2	38

KISSIMMEE SQUARE

1301 E. Vine Street, Kissimmee FL 34744



Archon Commercial Advisors is an affiliate of  SITE SOURCE